



E-3120 50kW Wind Turbine

The Endurance E-3120 wind turbine is designed to produce renewable energy efficiently, reliably, safely, and quietly. This turbine is ideal for larger farms, schools, hospitals, and commercial/industrial sites, and will produce 100,000 - 250,000 kWh per year in appropriate winds.

green energy that works



www.endurancewindpower.com

E-3120 Benefits

- ✦ Reduces the environmental footprint of your electrical energy supply
- ✦ Eligible for renewable energy credits
- ✦ Promotes community sustainability values
- ✦ Lowers and stabilizes energy costs
- ✦ Provides energy independence



E-3120 50kW Wind Turbine

- 1 Anemometer and wind vane
- 2 Lightning rod
- 3 Nacelle control cabinet
- 4 Induction generator
- 5 Fail-safe disk brake system
- 6 Gearbox
- 7 Access ladder
- 8 Yaw damper
- 9 Pitch control safety system
- 10 Fiberglass blade
- 11 Tower

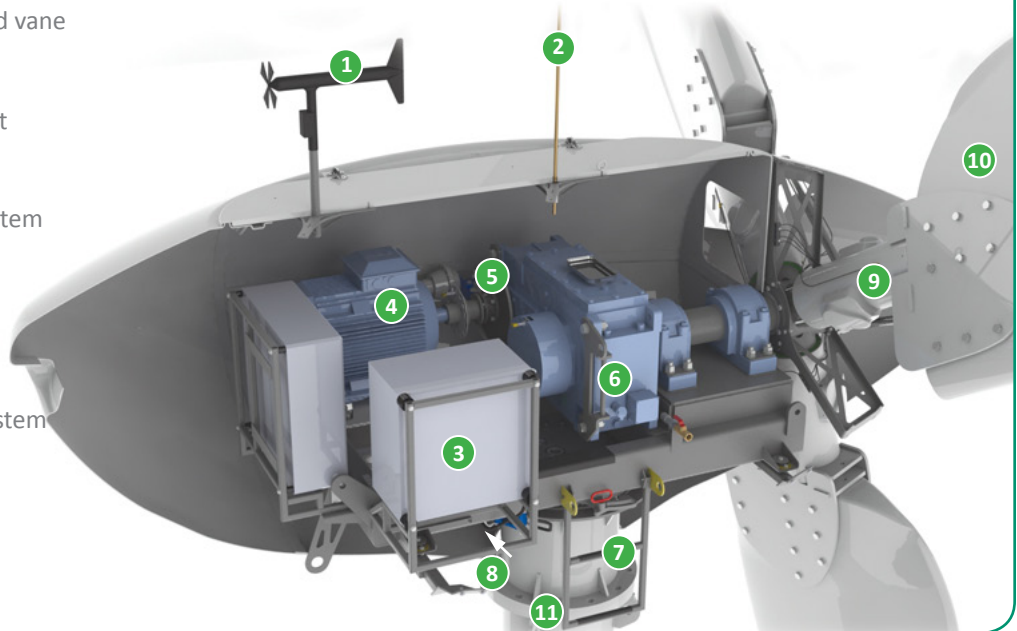

1 Anemometer and wind vane

Measures wind speed and direction to control starting, stopping, and orientation of the turbine to maximize power production.

2 Lightning rod

Guides lightning to the ground, protecting the turbine.

3 Nacelle control cabinet

Houses the tower-top electronics in a weather-protected environment for maximum reliability. The main turbine control panel is located at the base of the tower for easy access.

4 Induction generator

Delivers grid-compatible power and eliminates the need for an inverter or other power electronics. This improves efficiency and reliability, and reduces up-front costs.

5 Fail-safe disk brake system

Safely stops the wind turbine using twin brake calipers in situations such as extreme wind or grid failure.

6 Gearbox

Drives the generator at full speed while the rotor turns slowly. The gearbox uses rugged, conventional design for long life and high reliability.

7 Access ladder

Allows easy and safe access to the nacelle for maintenance. Safety is a top design priority.

8 Yaw damper

While the turbine is aerodynamically oriented by the wind, the yaw damper smooths the movement to ease tower and rotor loads.

9 Pitch control safety system

Provides backup protection against rotor over speed. If the rotor turns too fast for any reason, the blades are pitched by a spring mechanism to control the speed.

10 Fiberglass blade

Designed to quietly and efficiently produce energy, particularly in light winds.

11 Tower

Attractive monopole or economical lattice towers are available in sizes from 30.5 to 42.7 meters (100 to 140ft) to comply with height restrictions or reach the best winds at your site.

Cornerstones of Endurance Design

Production Efficiency

Most distributed wind customers did not select their site for wind resources, but look to generate power from the wind available to them. Endurance wind turbines are designed specifically for less-than-perfect wind conditions.

218,000 **KWH**
@7M/S **E-3120 50kW**
ANNUAL ENERGY PRODUCTION

Swept Area

The blades capture the energy of the wind. The larger the rotor diameter, the more wind energy the turbine captures. The Endurance E-3120 has a 19m (63 ft) rotor diameter- one of the largest rotor diameters per rated kW in its class- to capture the most wind energy.

Motoring

Motoring starts the blades spinning so the turbine operates in lighter wind conditions than if it relied solely on the wind to start (3-phase models only).

Generator Type

The induction generator produces electricity that can be transferred to the power grid without inverters. This provides lower equipment and maintenance costs and increases overall power production.

Reliability

All Endurance turbines have been extensively tested to ensure customers receive dependable energy production. They are built with proven commercial components for durability and easy support in the future.

Five Year Warranty

Endurance offers one of the best warranties in the wind industry, covering all defective components and labor for five years.

Safe Operation

When the turbine control system detects any fault, such as high wind or a grid power loss, the dual caliper disc brake system activates, safely stopping the turbine until the condition is cleared.

Passive Stall Rotor Design

The fixed-speed rotor aerodynamically stalls the blades as the first layer of protection for the turbine during high winds.

Control and Remote Interface Software

Each Endurance wind turbine is operated safely by an onboard computer system with advanced control logic. This system also records data including energy production, average power, wind speed and event history. Turbine controls and data are also remotely available from a web browser.

Quiet Operation

Quiet operation is essential for a wind turbine in a community environment. Endurance turbines use slowly turning blades and high-quality manufactured components to make them the quietest turbines in their class.

Clean Aesthetics

A wind turbine makes a powerful statement about your commitment to the environment and clean energy. Endurance wind turbines have clean lines and make an attractive addition to any landscape.

Turbine

Configuration	3 blades, horizontal axis, downwind
Rated power @ 9.5 m/s	50kW
Applications	Direct grid-tie
Rotor speed	42 rpm
Cut-in wind speed	3.5 m/s (7.8 mph)
Cut-out wind speed	25 m/s (56 mph)
Survival wind speed	52 m/s (116 mph)
Overall weight	3 990 kg (8 800 lbs)

Rotor

Rotor diameter	19.2 m (63.0 ft)
Swept area	290 m ² (3120 ft ²)
Blade length	9.00 m (29.5 ft)
Blade material	Fiberglass/Polyester
Power regulation	Stall control (constant speed)

Generator

Type	Induction generator
Configurations	3 ϕ , 480 VAC or 600 VAC @ 60 Hz 1 ϕ , 240VAC @ 60Hz

Brake & Safety Systems

Main brake system	Rapid fail-safe dual mechanical brakes
Secondary safety	Pitch control system (for over-speed regulation) using passive, spring-loaded mechanism

Automatic shut down triggered by :

- High wind speed
- Grid failure
- Over-speed
- All other fault conditions

Controls

Control System	Programmable logic controller (PLC)
User interface	Wireless or wired network software interface for remote monitoring and control

Warranty

Turbine & controls	5 years parts and labour
--------------------	--------------------------

Towers

Free-standing monopole or lattice:	30.5m (100 ft), 36.5m (120 ft), 42.7m (140 ft)
Maintenance access	Safe climbing system Working space inside the nacelle Tower-top work platform

Power Curve

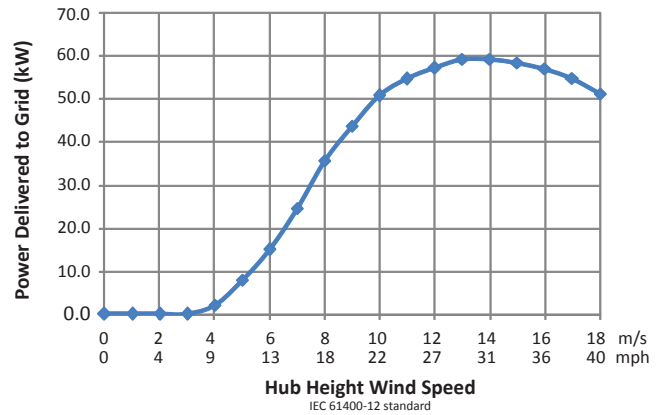

Annual Energy Production (AEP)

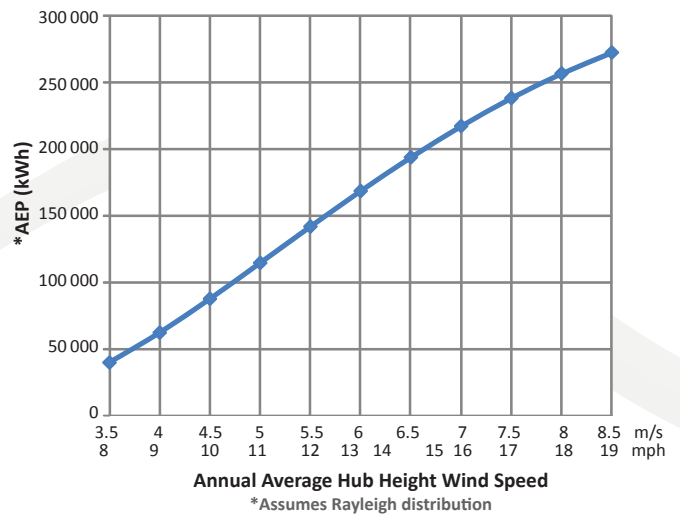

Annual Average Hub Height Wind Speed (m/s)	Annual Energy Production (kWh)
3.5	40 100
4.0	62 500
4.5	88 000
5.0	114 900
5.5	142 200
6.0	168 900
6.5	194 300
7.0	217 700
7.5	238 800
8.0	257 200
8.5	273 000

Wind Speed Conversion Table

m/s	4	5	6	7	8	9	10	11	12	14
km/h	14	18	22	25	29	32	36	40	43	50
mph	9	11	13	16	18	20	22	25	27	31

www.endurancwindpower.com
info@endurancwindpower.com



Endurance Wind Power uses 100% renewable energy at its head office and manufacturing plant